



SISTEMA DE GESTIÓN DE COMBUSTIBLE



DISPENSADORES



KITS



BOMBAS



MEDIDORES



PISTOLAS

K24

CARACTERÍSTICAS

- PRESIÓN DE ROTURA DE 100 BAR
- PANTALLA LCD
- INDICADOR DE CAUDAL
- FÁCIL DE CALIBRAR

PIUSI K24 es un caudalímetro digital de turbina específicamente diseñado para el combustible diésel. Fácil de instalar en línea o al final del tubo de suministro, viene equipado con una pantalla giratoria. Este medidor se encuentra disponible con cuerpo de aluminio o de tecnopolímero.

RENDIMIENTO

7-120

L/MIN
CAUDAL

20 BAR
FUNCIONAMIENTO
MÁX.

PRESIÓN

± 1%

PRECISIÓN

0,2%

REPETIBILIDAD



K24 VERSIÓN DE PLÁSTICO



K24 PULSER

K24

PACKAGING

CÓDIGO	PESO		PACKAGING		
	KG	LBS	MM	PULGADAS	UDS./CAJA
K24					
FOO40700A	0,5	1,1	BLÍSTER	BLÍSTER	1
FOO408100	0,5	1,1	BLÍSTER	BLÍSTER	1
K24 PULSER					
FOO40722A	0,5	1,1	115X16OX135	4,5X6,3X5,3	1



FILTRACIÓN



MONITOREO DE DEPÓSITO



ENROLLADORES DE MANGUERA



ACCESORIOS



MATERIAL PROMOCIONAL



AIRE



ANTICONG.



AdBlue®



BIODIÉSEL



DIÉSEL



ALIMENTOS



GASOLINA



GRASA



QUEROSENO



ACEITE



AGUA



LIMPIAPARAB.

GRÁFICO

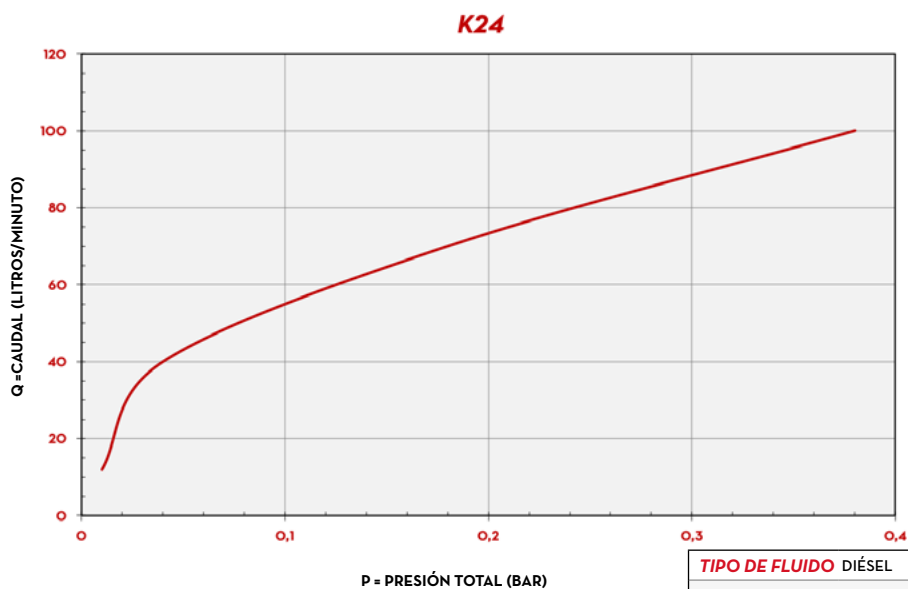

DIMENSIONES

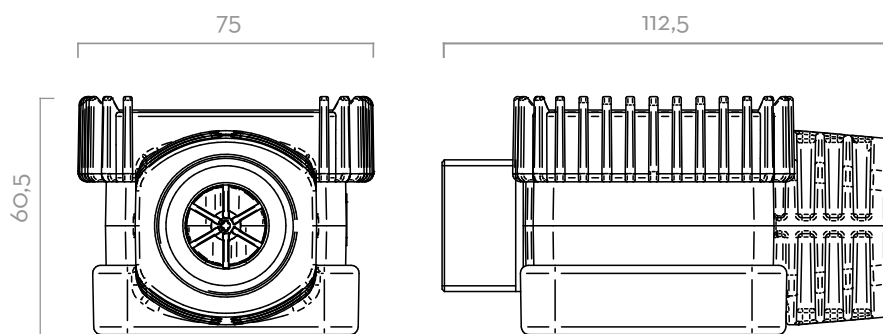

Las dimensiones se expresan en milímetros

CONTENIDO DE LA CAJA

- MEDIDOR K24
- TOMA F/F
- MANUAL DE INSTRUCCIONES

DETALLES



MATERIALES

- CUERPO: ALUMINIO
- ENGRANAJES: TECNOPOLÍMERO

FICHA TÉCNICA

CÓDIGO	DESCRIPCIÓN	TIPO DE FLUIDO	CAUDAL		PRESIÓN		PILAS 2X AAA PILAS 1.5V (INCLUIDO)	BRIDA	ENTRADA/SALIDA
			L/MIN	GPM	BAR	PSI			
K24									
FOO40700A	K24 METER M/MF LITER BLACK 1INBSP	D	7 - 120	2 - 32	10	150	SÍ	NO	M 1" BSP - M 1" BSP
FOO408100	K24 M/F 1" BSP	D	7 - 120	2 - 32	20	300	SÍ	NO	M 1" BSP - F 1" BSP
K24 PULSER									
FOO40722A	K24 PULSER M/MF LITER BLACK 1INBSP	D	7 - 120	2 - 32	10	150	NO	NO	M 1" BSP - M 1" BSP

SE PUEDE PEDIR EN VERSIÓN NPTF Y PANTALLA EN GALONES/CUARTOS O PINTAS
2 PILAS DE 1,5 V INCLUIDAS

K24